

DX80e

Skid à chenilles

Caractéristiques principales

Paramètres

Moteur	Briggs & Stratton / Kohler
Puissance	17,15 kw / 23 HP
Energie	Essence
Régime moteur	3600 tr/min
Pression hydraulique	170 bars
Débit hydraulique	50 L/min
Poids opérationnel	855 kg

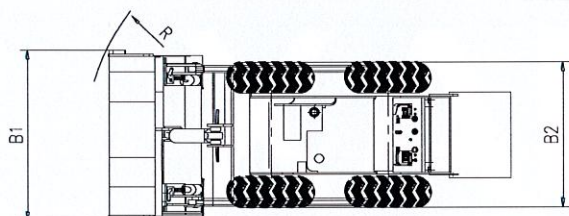
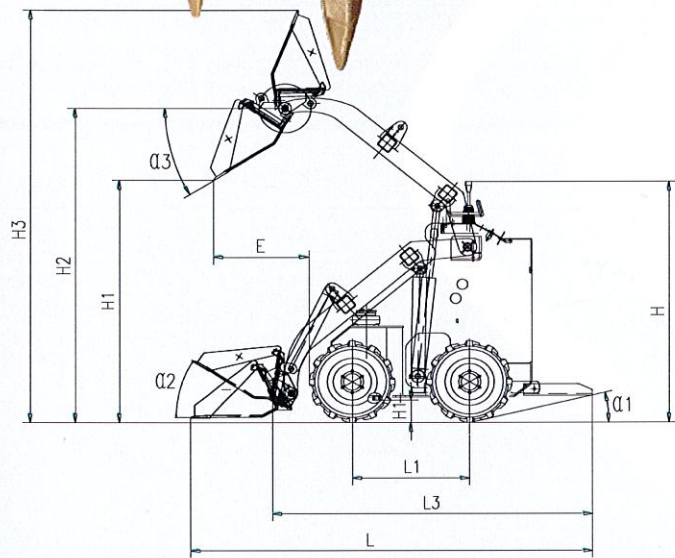

Dimensions

H1	1386 mm	E	471 mm
H2	1803 mm	$\alpha 1$	18°
H3	2065 mm	$\alpha 2$	33°
H	1309 mm	$\alpha 3$	32°
L1	690 mm	B1	820 mm
L3	1778 mm	B2	800 mm
L	2210 mm	H	1309 mm

